



ToolSens8 User's manual

Version: v1.00



Please read the following notes

1. All information included in this document is current as of the date this document is issued. Such information, however, is subject to change without any prior notice.
2. PoLabs does not assume any liability for infringement of patents, copyrights, or other intellectual property rights of third parties by or arising from the use of PoLabs products or technical information described in this document. No license, express, implied or otherwise, is granted hereby under any patents, copyrights or other intellectual property rights of PoLabs or others. PoLabs claims the copyright of, and retains the rights to, all material (software, documents, etc.) contained in this release. You may copy and distribute the entire release in its original state, but must not copy individual items within the release other than for backup purposes.
3. Descriptions of circuits, software and other related information in this document are provided only to illustrate the operation of the products and application examples. You are fully responsible for the incorporation of these circuits, software, and information in the design of your equipment. PoLabs assumes no responsibility for any losses incurred by you or third parties arising from the use of these circuits, software, or information.
4. PoLabs has used reasonable care in preparing the information included in this document, but PoLabs does not warrant that such information is error free. PoLabs assumes no liability whatsoever for any damages incurred by you resulting from errors in or omissions from the information included herein.
5. PoLabs devices may be used in equipment that does not impose a threat to human life in case of the malfunctioning, such as: computer interfaces, office equipment, communications equipment, test and measurement equipment, audio and visual equipment, home electronic appliances, machine tools, personal electronic equipment, and industrial robots.
6. Measures such as fail-safe function and redundant design should be taken to ensure reliability and safety when PoLabs devices are used for or in connection with equipment that requires higher reliability, for example: traffic control systems, anti-disaster systems, anticrime systems, safety equipment, medical equipment not specifically designed for life support, and other similar applications.
7. PoLabs devices shall not be used for or in connection with equipment that requires an extremely high level of reliability and safety, as for example: aircraft systems, aerospace equipment, nuclear reactor control systems, medical equipment or systems for life support (e.g. artificial life support devices or systems), and any other applications or purposes that pose a direct threat to human life.
8. You should use the PoLabs products described in this document within the range specified by PoLabs, especially with respect to the maximum rating, operating supply voltage range and other product characteristics. PoLabs shall have no liability for malfunctions or damages arising out of the use of PoLabs products beyond such specified ranges.
9. Although PoLabs endeavors to improve the quality and reliability of its products, semiconductor products have specific characteristics such as the occurrence of failure at a certain rate and malfunctions under certain use conditions. Further, PoLabs products are not subject to radiation resistance design. Please be sure to implement safety measures to guard them against the possibility of physical injury, and injury or damage caused by fire in the event of the failure of a PoLabs product, such as safety design for hardware and software including but not limited to redundancy, fire control and malfunction prevention, appropriate treatment for aging degradation or any other appropriate measures.
10. Usage: the software in this release is for use only with PoLabs products or with data collected using PoLabs products.
11. Fitness for purpose: no two applications are the same, so PoLabs cannot guarantee that its equipment or software is suitable for a given application. It is therefore the user's responsibility to ensure that the product is suitable for the user's application.
12. Viruses: this software was continuously monitored for viruses during production, however the user is responsible for virus checking the software once it is installed.
13. Upgrades: we provide upgrades, free of charge, from our web site at www.poscope.com. We reserve the right to charge for updates or replacements sent out on physical media.
14. Please contact a PoLabs support for details as to environmental matters such as the environmental compatibility of each PoLabs product. Please use PoLabs products in compliance with all applicable laws and regulations that regulate the inclusion or use of controlled substances, including without limitation, the EU RoHS Directive. PoLabs assumes no liability for damages or losses occurring as a result of your noncompliance with applicable laws and regulations.
15. Please contact a PoLabs support at support@poscope.com if you have any questions regarding the information contained in this document or PoLabs products, or if you have any other inquiries.
16. The licensee agrees to allow access to this software only to persons who have been informed of and agree to abide by these conditions.
17. Trademarks: Windows is a registered trademark of Microsoft Corporation. PoKeys, PoKeys55, PoKeys56U, PoKeys56E, PoKeys57U, PoKeys57E, PoKeys57CNC, PoKeys57CNCpro4x25, PoKeys57CNCdb25, PoScope, PoLabs and others are internationally registered trademarks.

Contents

1. Introduction.....	4
2. Features.....	5
3. Technical specifications.....	6
3.1. ToolSens8 dimensions.....	6
3.2. Maintenance.....	7
4. Errata information.....	9
5. Change log.....	10
6. Grant of license	11

1. Introduction

The ToolSens8 Laser Tool Measurement Sensor is a precision optical sensor designed for automated tool detection and measurement in CNC machines. This device offers a compact and accurate solution to ensure precise tool measurements during CNC operation and setup. It integrates seamlessly into automated machining systems to improve efficiency and production quality.

Why is it useful?

In CNC operations, maintaining precise tool dimensions and positioning is critical to ensure consistent machining quality. The ToolSens8 sensor automatically detects and measures the tool length with a high degree of accuracy (± 0.001 mm), eliminating manual inspection errors and reducing downtime. It can also measure diameter with advanced but intuitive probing cycles. Its non-contact laser measurement system enhances the longevity of both the sensor and the tools by minimizing wear and contamination. Non-contact means that it doesn't need to touch the measuring surface, which means there is no risk of fracture of the already fragile cutting edge.

2. Features

- High-precision laser measurement (± 0.001 mm)
- Wide diameter detection range (0.05–8.00 mm)
- No physical contact with tool — reduces wear and contamination
- Compact design suitable for integration into all kinds of CNC machines
- IP50-rated housing for dust resistance
- Low air pressure cleaning during measuring – avoids tool damage while ensuring clean measurements

Benefits:

- Increased production efficiency by automating tool measurement
- Reduced tool breakage and wear due to early detection of anomalies
- Enhanced product quality with consistent machining precision
- Lower maintenance cost due to laser sensor and increased tool life
- Simplified integration into existing CNC systems

3. Technical specifications

Specification	Details
Model	ToolSens8
Operating Temperature	10°C ~ 40°C
Protection Class (IP)	IP50
Measurement Diameter Range	0.05 mm ~ 8.00 mm
Measurement Accuracy	±0.001 mm
Sensor Lifetime	5 years (continuous operation, no external damage)

Wire Color	Signal Name	Function
Black	GND	Ground line – 0 V
Red	5 V	Power supply line – 5 V
White	Enable input signal	Activates the sensor
Orange	Output signal	Push-pull output 0 V / 5 V with 10 mA sink/source capability, 1.5 us rise time

Enable input signal	Laser beam	Output signal
0 V	Interrupted	0 V
0 V	Not interrupted	5 V
5 V	-	0 V
Ni priključen	-	0 V

3.1. ToolSens8 dimensions

Measurements are in mm.

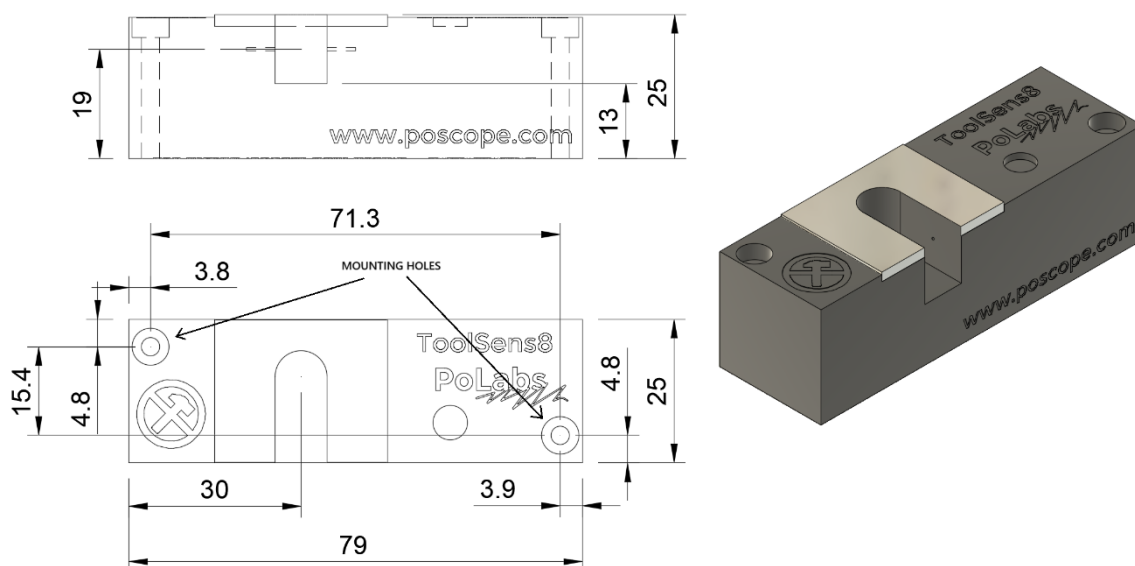

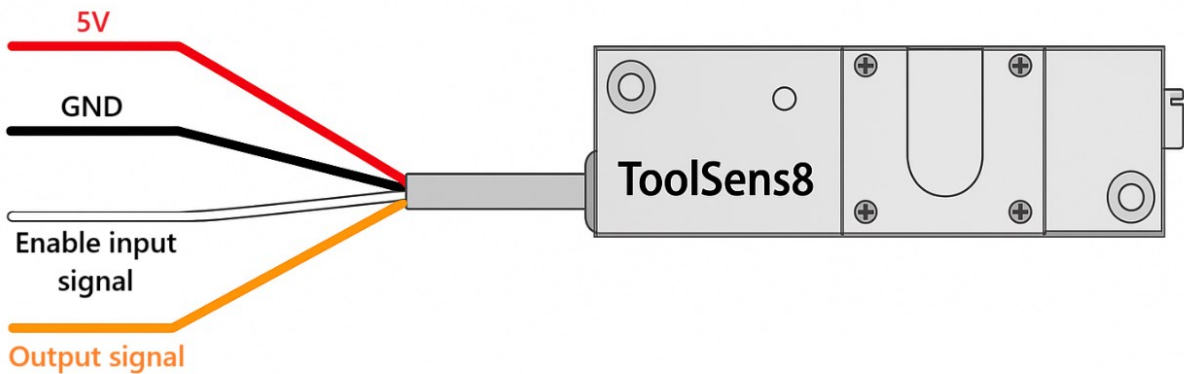

3.2. Maintenance

The lens of the laser needs cleaning. Due to dust and chips in the CNC environment fine particles accumulate on the lens. The laser inside the ToolSens is protected with glass cover so nothing can get inside the device. It is still recommended to clean glass lens with pressured air (gently blow on the lens) or wiping the lens with fiber cloth or cotton swab.

When lens are not clean, the red LED on the housing (beam interruption indicator) will flicker because of the lens contamination.

3.3. Air tool cleaning

ToolSens8 enables the user to use compressed air to clean tool when measuring. It uses 4mm quick fitting to connect air supply to the sensor. The compressed air has to be switched with outside solenoid/unit so it is supplied only when measuring.



3.4. Mach3 & Mach4 settings

For Mach settings please check out the following blog posts:

<https://blog.poscope.com/mach4-probing/>

<https://blog.poscope.com/cnc-tool-setter-with-pokeys-and-mach4/>

Both are for probing and tool setting but they also have information about different G-codes that are used in probing cycles and for setting the appropriate tool offsets in Mach.

4. Errata information

5. Change log

V1.00 initial revision

6. Grant of license

The material contained in this release is licensed, not sold. PoLabs grants a license to the person who installs this software, subject to the conditions listed below.

Access

The licensee agrees to allow access to this software only to persons who have been informed of and agree to abide by these conditions.

Usage

The software in this release is for use only with PoLabs products or with data collected using PoLabs products.

Copyright

PoLabs claims the copyright of, and retains the rights to, all material (software, documents etc) contained in this release. You may copy and distribute the entire release in its original state, but must not copy individual items within the release other than for backup purposes.

Liability

PoLabs and its agents shall not be liable for any loss or damage, howsoever caused, related to the use of PoLabs equipment or software, unless excluded by statute.

Fitness for purpose

No two applications are the same, so PoLabs cannot guarantee that its equipment or software is suitable for a given application. It is therefore the user's responsibility to ensure that the product is suitable for the user's application.

Mission Critical applications

Because the software runs on a computer that may be running other software products, and may be subject to interference from these other products, this license specifically excludes usage in 'mission critical' applications, for example life support systems.

Viruses

This software was continuously monitored for viruses during production, however the user is responsible for virus checking the software once it is installed.

Support

No software is ever error-free, but if you are unsatisfied with the performance of this software, please contact our technical support staff, who will try to fix the problem within a reasonable time.

Upgrades

We provide upgrades, free of charge, from our web site at www.poscope.com. We reserve the right to charge for updates or replacements sent out on physical media.

Trademarks

Windows is a registered trademark of Microsoft Corporation. PoKeys, PoKeys55, PoKeys56U, PoKeys56E, PoKeys57E, PoKeys57U, PoKeys57CNC, PoKeys57CNCpro4x25, PoStep25, PoStep60, PoScope, PoLabs and others are internationally registered trademarks.

support: www.poscope.com